



**GEDA USA, LLC**

1151 Butler Rd. • League City, TX 77573

Phone: 713-621-7272 • Fax: 713-621-7279 • Toll-Free: 1-866-973-4332

[www.gedausa.com](http://www.gedausa.com) • [sales@gedausa.com](mailto:sales@gedausa.com)

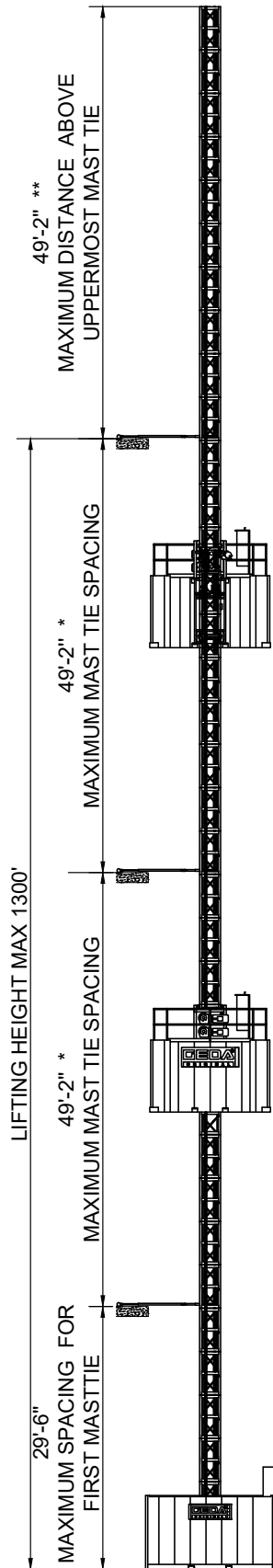

**ELEVATION VIEW**

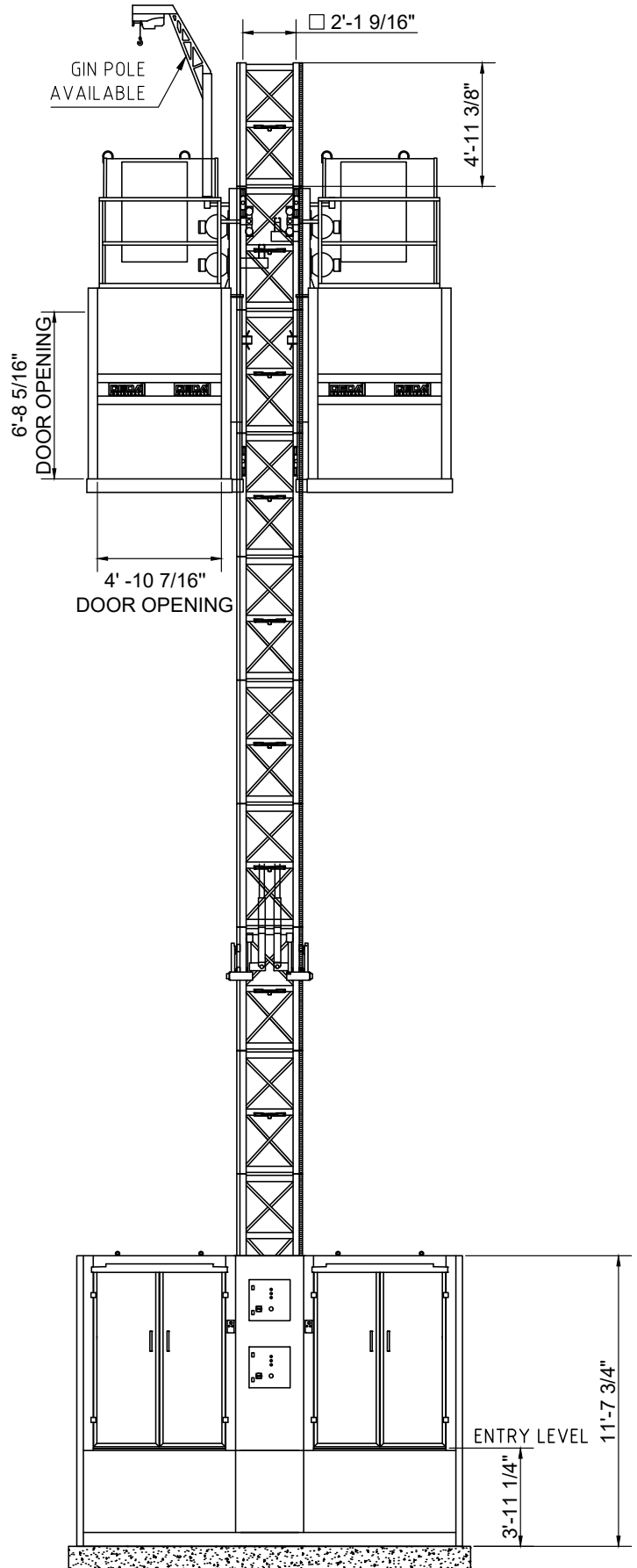

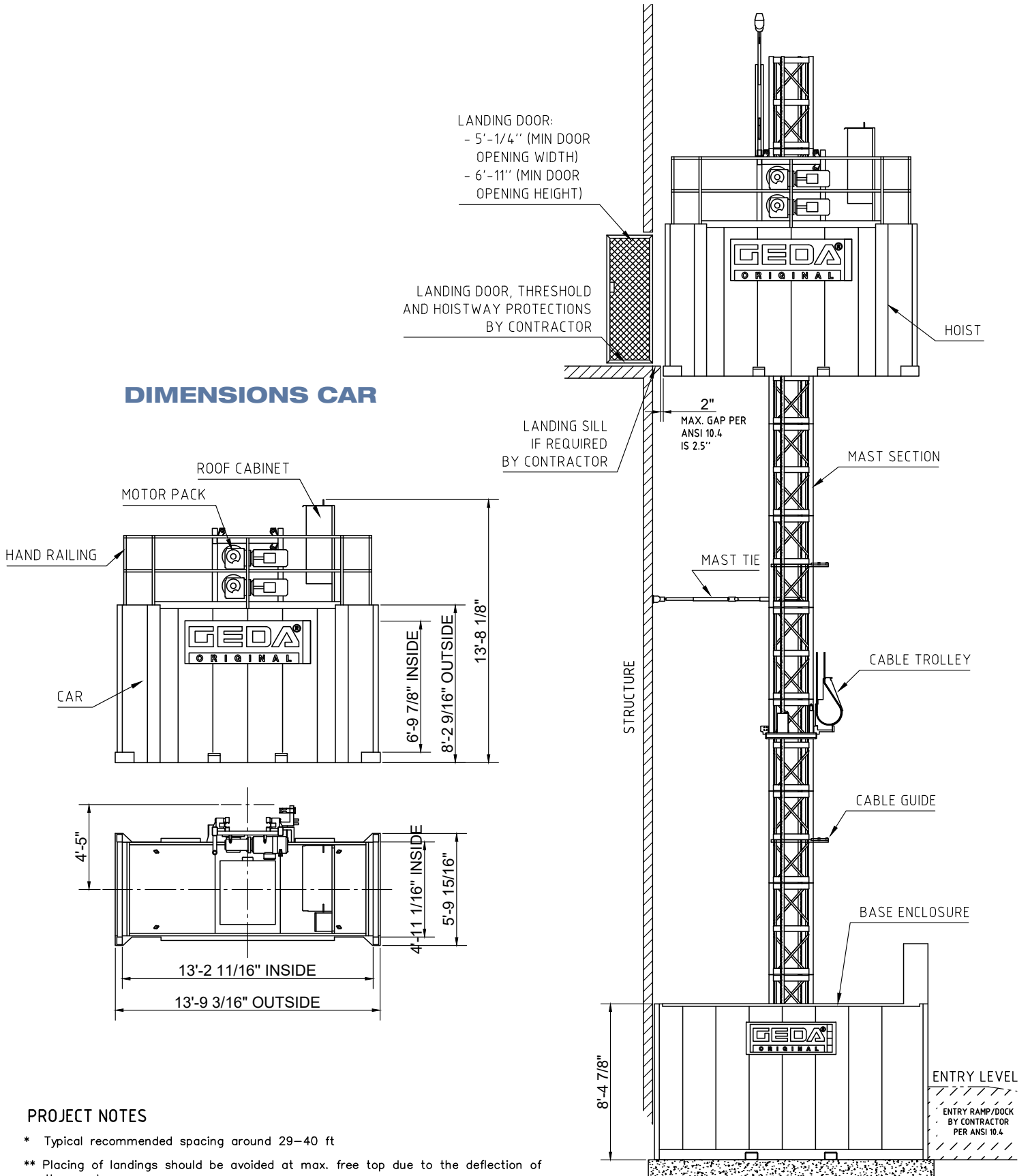

**PROJECT NOTES**

- \* Typical recommended spacing around 29-40 ft
- \*\* Placing of landings should be avoided at max. free top due to the deflection of the mast.

## TIE-IN DETAILS - SLAB MOUNTED

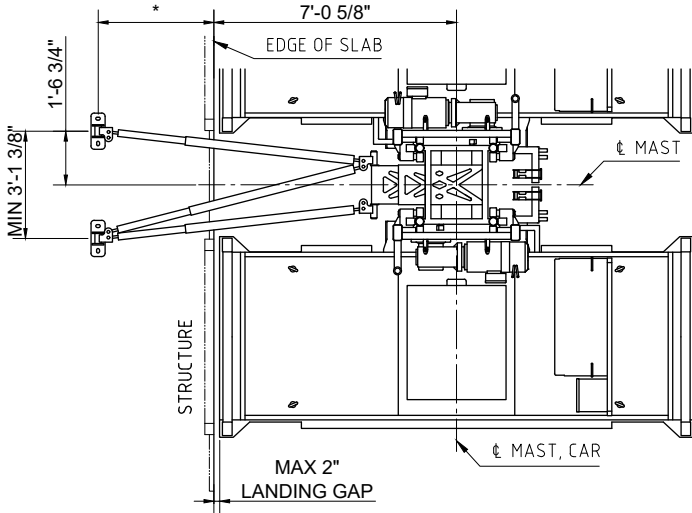

### ELEVATION VIEW

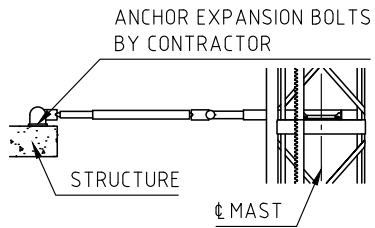

## TIE-IN DETAILS - SLAB MOUNTED WITH LANDING SILL

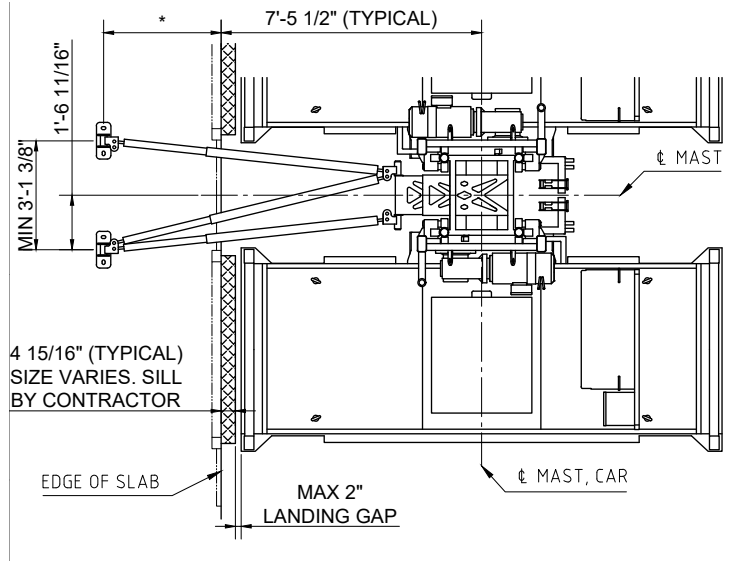

### INCLINATION DETAILS

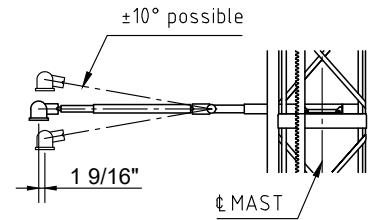

## TIE-IN PLATE

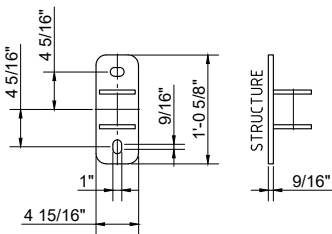

ADDITIONAL TIE-IN PLATES TO DISTRIBUTE THE ANCHOR LOADS REQUIRED (DEPENDING ON SITE CONDITIONS)

## ATTACHMENT POINTS

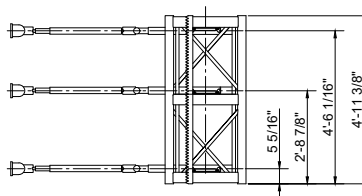

## TIE-IN LOADS

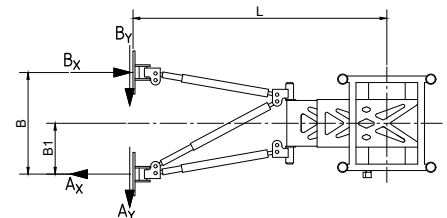

PLEASE SEE GEDA INSTALLATION MANUAL FOR TIE-IN LOADS

ALTERNATE MAST TIES OR ANCHORING DISTANCES AVAILABLE. CONTACT GEDA FOR INFORMATION.

## TIE-IN DETAILS - WALL MOUNTED

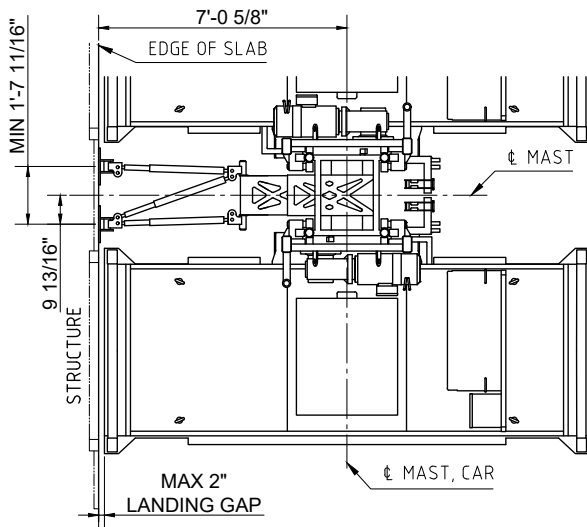

**ELEVATION VIEW**

## TIE-IN DETAILS - WALL MOUNTED WITH LANDING SILL

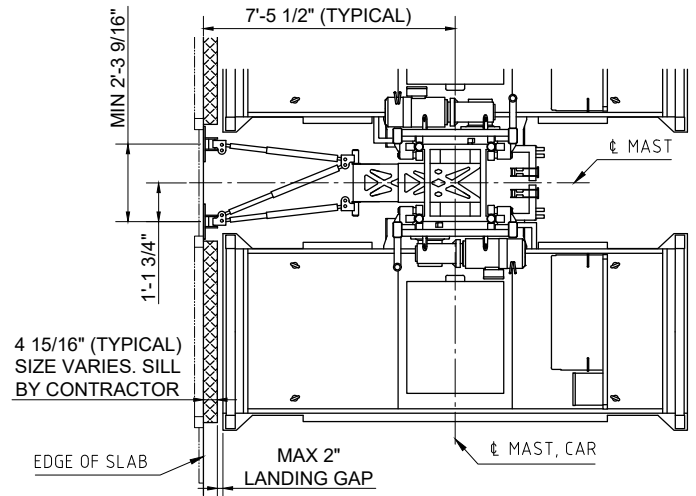

**INCLINATION DETAILS**

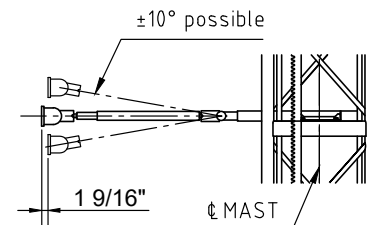
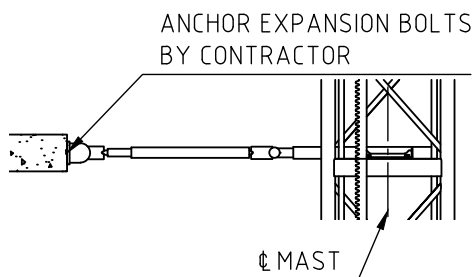

### PROJECT NOTES

- \* Distance to slab depending on site conditions (e. g. quality of concrete, wind loads, typ of ancore, ...)

## PLAN VIEW BASE ENCLOSURE

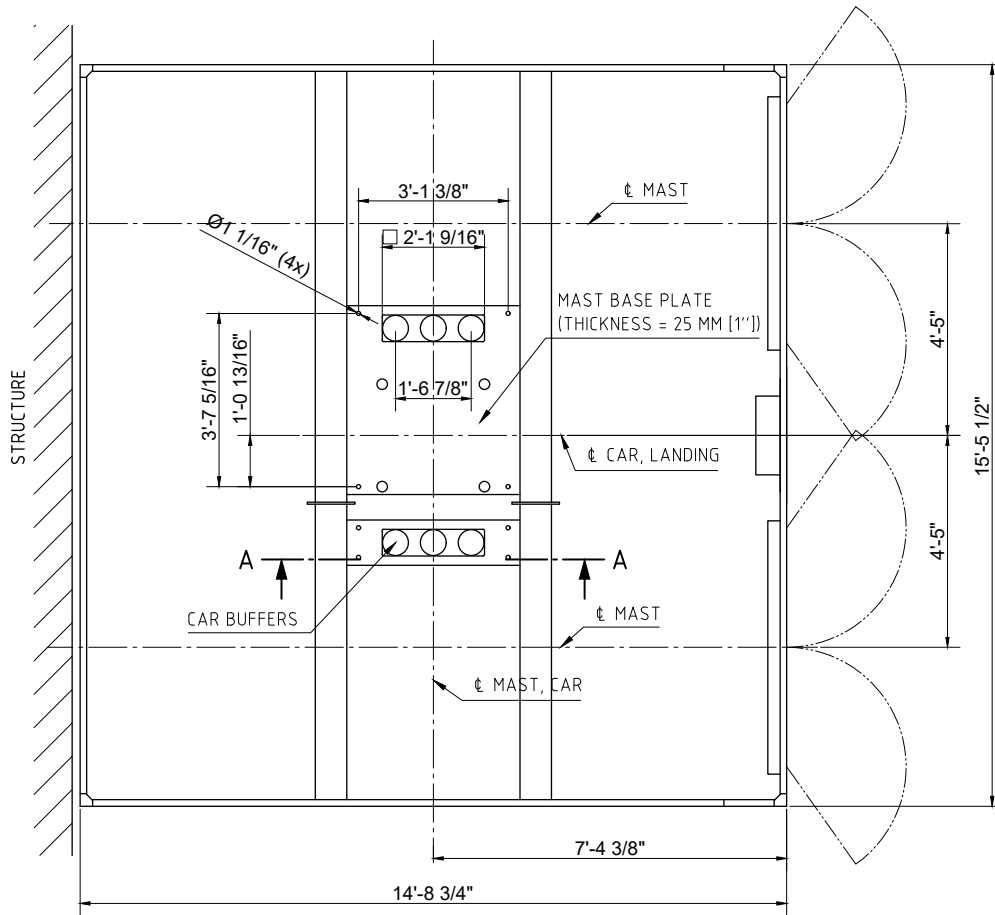

## MAST BASE

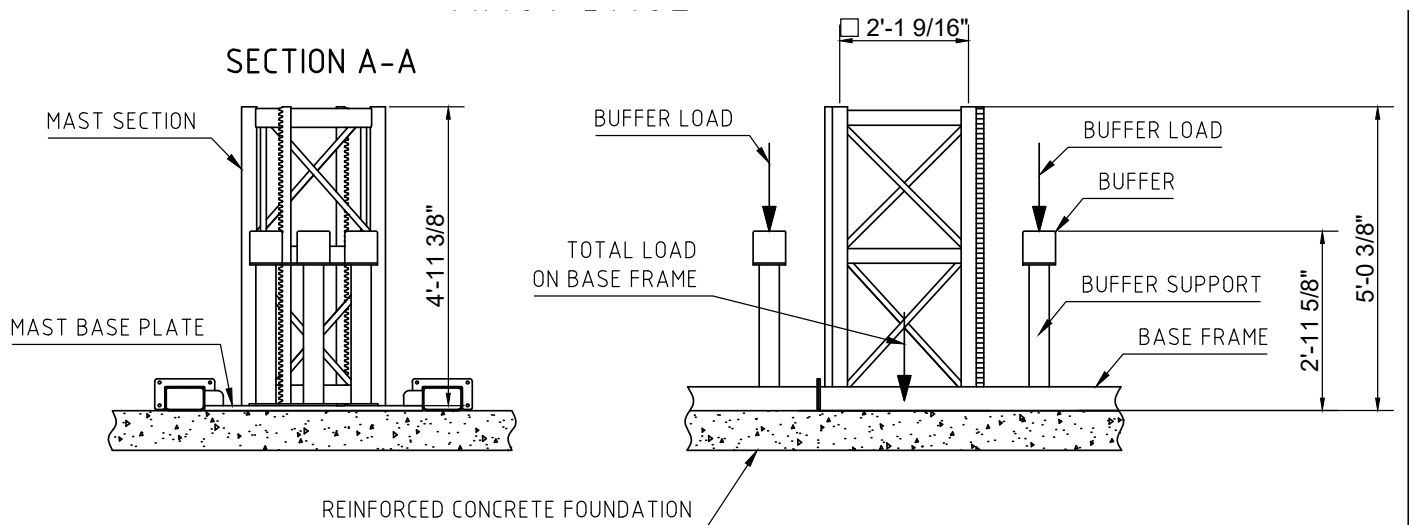

PLEASE SEE GEDA INSTALLATION MANUAL FOR TOTAL LOAD ON BASE FRAME AND BUFFER LOAD.

## FOUNDATION PLAN VIEW

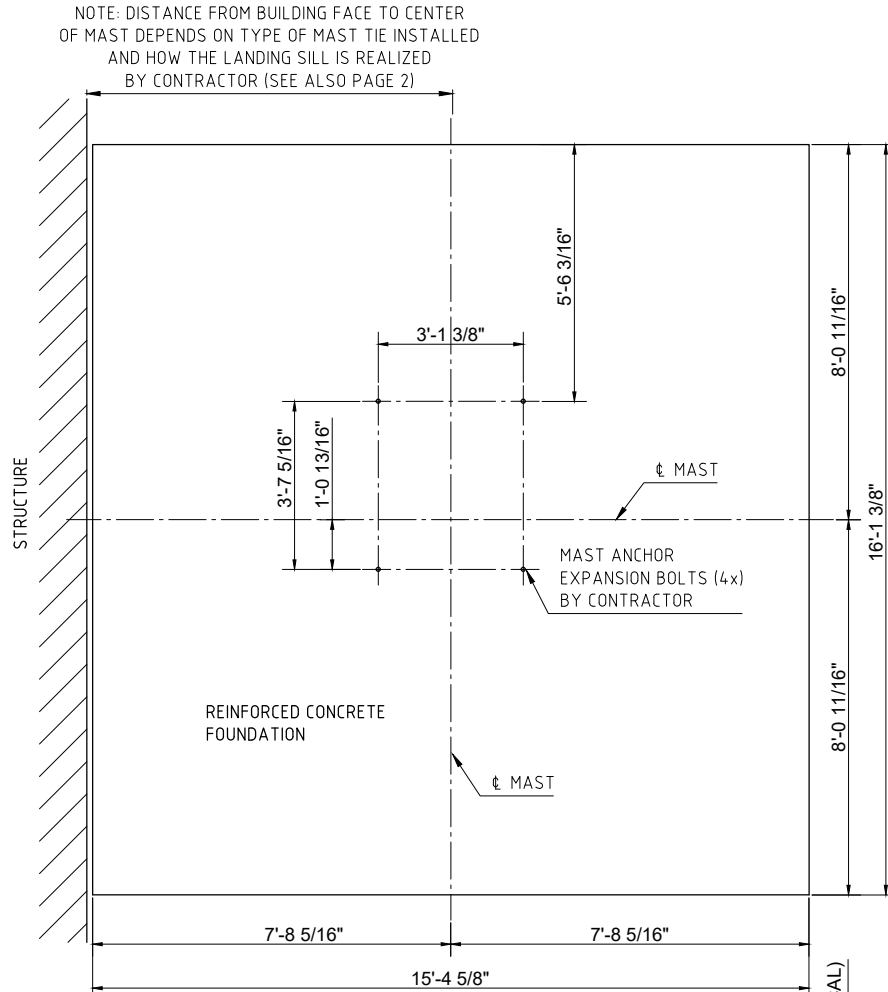

## FOUNDATION SIDE VIEW

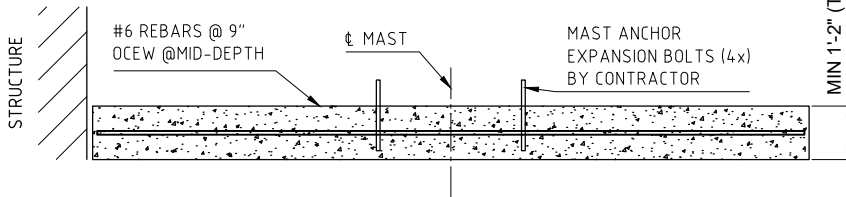

### FOUNDATION NOTES:

1. FOUNDATION BASED ON 310' MAST HEIGHT.
2. FOR MAST HEIGHTS ABOVE 310', PLEASE CONTACT OUR ENGINEERING DEPARTMENT FOR DESIGN SPECIFICATIONS.
3. FOUNDATION DESIGNED FOR MINIMUM SOIL BEARING OF 1250 PSF.
4. CONSTRUCTION SHALL BE IN ACCORDANCE WITH THE GOVERNING INTERNATIONAL BUILDING CODE.
5. STEEL REINFORCEMENT SHALL CONFORM TO ASTM A615 GRAD 60.

# SPECIFICATIONS

## MACHINE TECHNICAL DATA SPECS

MACHINE TYPE:	GEDA PH7000
CONFIGURATION:	DUAL
CAPACITY:	7000 POUNDS
LIFTING HEIGHT:	VARIABLE (MAX 400m)
RATED SPEED:	196 ft/min.
NUMBER OF MOTORS:	2x31.5 kW (105 Hz)
MOTOR PACK TYPE:	VFC

## COMPONENTS WEIGHT

BASE ENCLOSURE:	4200 LBS
CAR:	4200 LBS
MOTORPACK:	1950 LBS
ROOF CABINET:	600 LBS
MAST SECTION DUAL:	390 LBS
MAST TIE:	230 LBS
CABLE GUIDE	12.5 LBS
CABLE TROLLEY:	165 LBS

## POWER SUPPLY REQUIREMENTS (PER CAR)

VOLTAGE:	480 V, 3 PHASE	FREQUENCY:	60 HZ
MAINS FUSES:	100 A	POWER CONSUMPTION	95 kVA

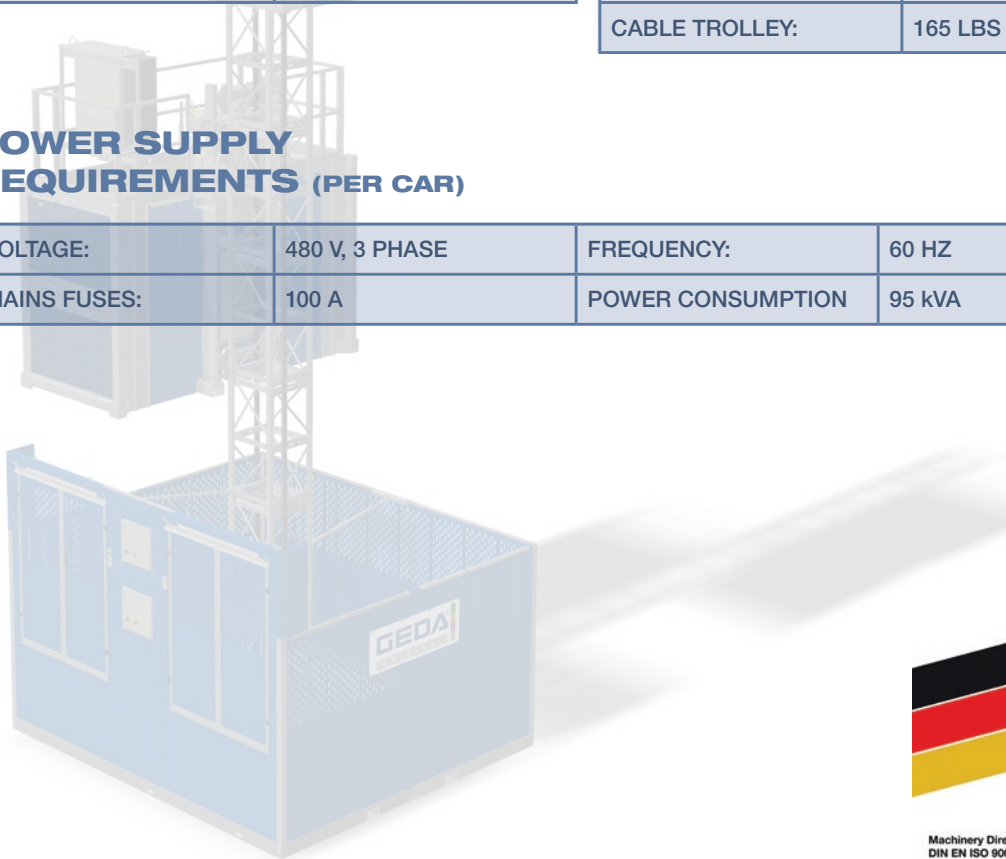

Machinery Directive 2006/42/EG  
DIN EN ISO 9001:2008

